

## STOR-PAK 63

**With 3 Drawers.**  
**Made from High Impact Styrene.**

- STACKABLE
- FITS ON STOR-PAK 60
- UNIQUE SAFETY LATCHES
- FITS ONTO LOUVRE PANEL
- TWO REMOVABLE DIVIDERS IN EACH DRAWER

**IDEAL FOR:**

- HANDYPERSON
- TRADESPERSON
- OFFICE
- HOME
- WORK VANS

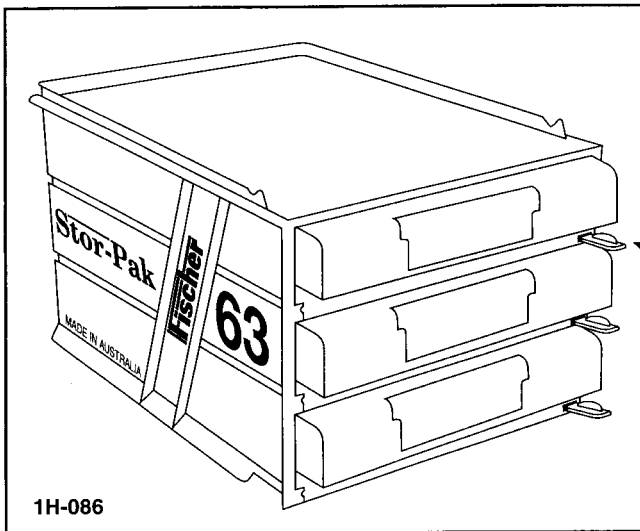

205W x 285D x 160H mm

Unique safety latches ensure drawers remain shut.

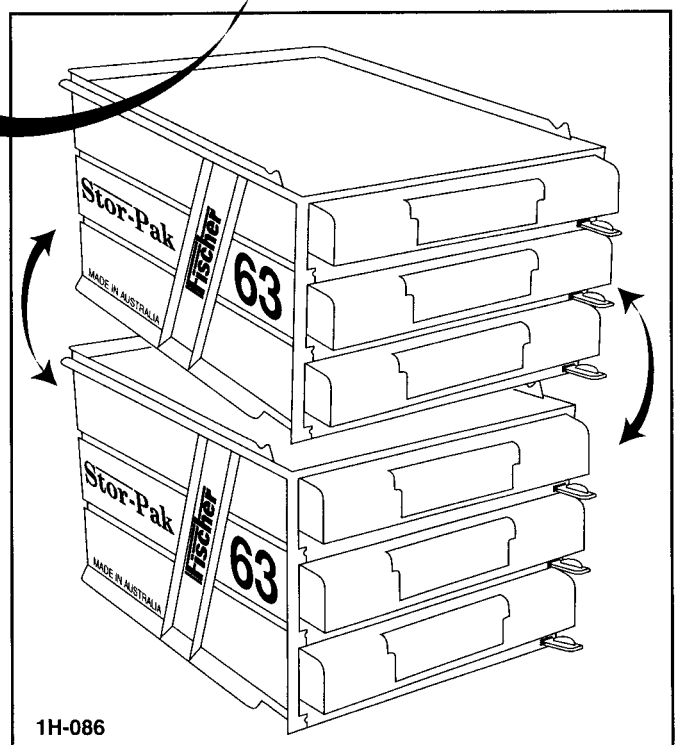

**Drawer size inner measurement**  
 185W x 250D x 40H mm

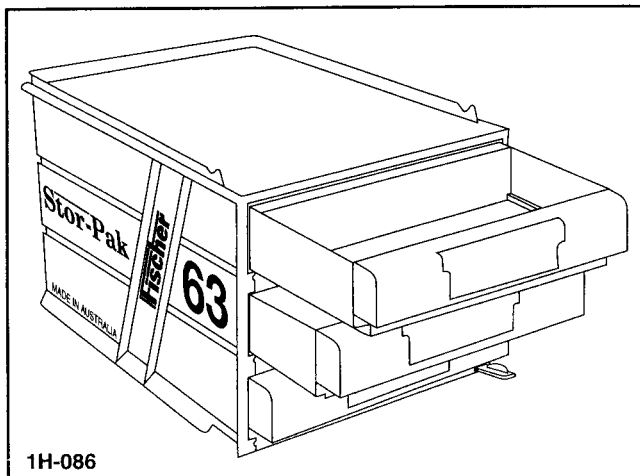

CODE	DESCRIPTION	CTN. QTY
1H-086	Stor-Pak 63 - Grey Outer/Blue Trays	3